

**Serie**

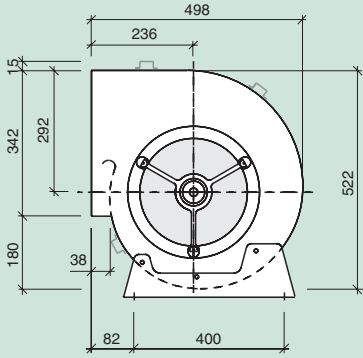

**L**

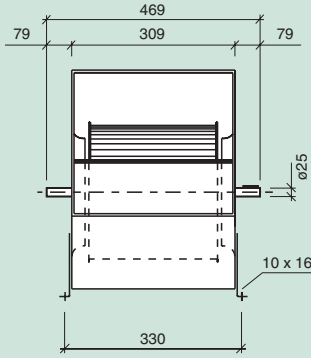

**T2L**

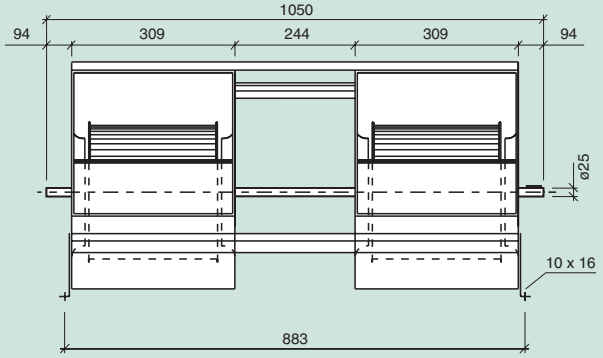

**Serie**

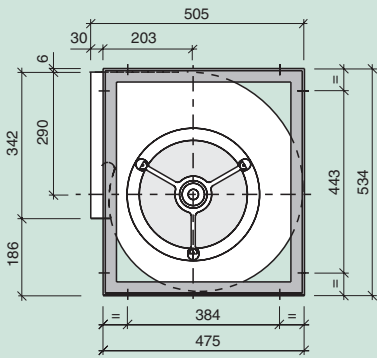

**SR**

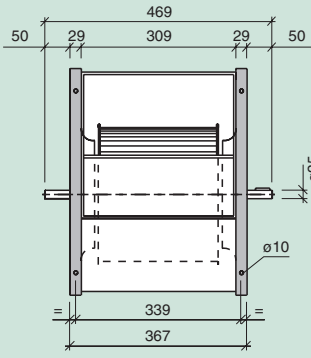

**T2SR**

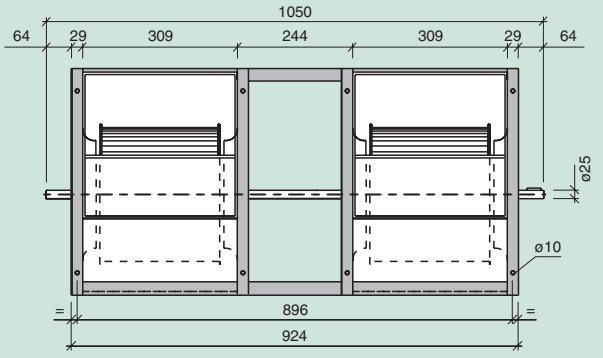

**Serie**

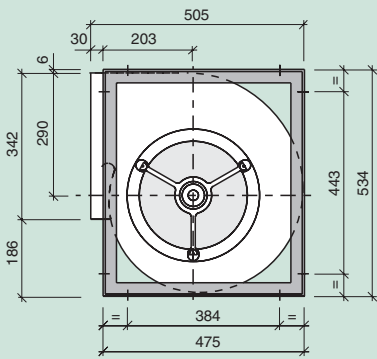

**R**

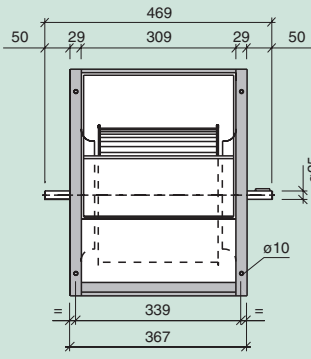

**Serie**

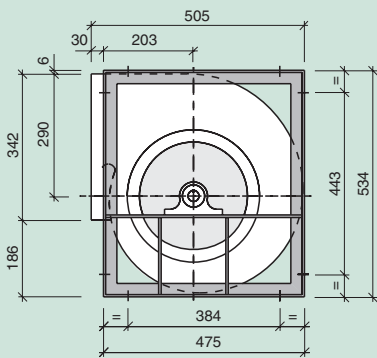

**T2R**

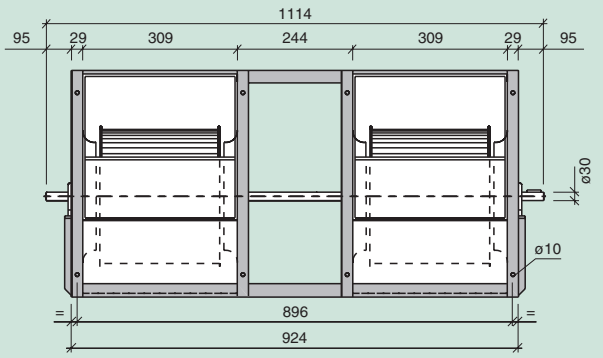

Serie - Series - Serie		L	SR	R	T2L	T2SR	T2R	T3R	
<b>Límite de empleo.</b> Operational limit. Limite d'emploi.	n max. motor max.	rpm kW	1500 2.2	1600 3	1800 3.5	1400 3	1600 3.5	1800 5.5	1400 7
<b>Velocidad tangencial.</b> Tip speed. Vitesse tangentielle.	u	m/s	n (min <sup>-1</sup> ) x 0.0169						
<b>Momento de inercia.</b> Moment of inertia. Moment d'inertie.	PD <sup>2</sup> /4	Kg m <sup>2</sup>	0.09	0.09	0.09	0.18	0.18	0.18	0.27
<b>Peso del ventilador.</b> Fan weight. Poids du ventilateur.		Kg	13.5	17	18	30	33	44.5	70
<b>Coefficientes de corrección.</b> Correction factors. Coefficients de correction.	V P <sub>A</sub> n	m <sup>3</sup> /h kW min <sup>-1</sup>	x 1 x 1 x 1	x 1 x 1 x 1	x 1 x 1 x 1	x 2 x 2.15 x 1.05	x 2 x 2.15 x 1.05	x 2 x 2.15 x 1.05	x 3 x 3.25 x 1.08

